

LXZS Magnetic Return Filter with check valve



Technical specification

Application:	Magnetic return filter with check valve
Port options:	Threaded
Flow rate:	max. 160; 400 l/min
Working pressure:	max. 16 bar
By-pass opening pressure:	Δp 4 bar + 10%
Clogging indicator setting:	Δp 3.5 bar \pm 10%
Material:	Aluminium
Compatibility:	Water-glycol & hydraulic oil
Tested according to ISO standards:	<ul style="list-style-type: none"> ISO2941 Collapse/burst resistance ISO2942 Fabrication integrity ISO2943 Material compatibility integrity ISO3723 Method for end load test ISO3724 Flow fatigue characteristics ISO3968 Pressure drop vs. Flow ISO16889 Multi-pass (filtration performance)

Technical specification subject to change without prior notice. Other specification on request 013/07/23

FILTER SELECTOR

Select your filter requirements here.

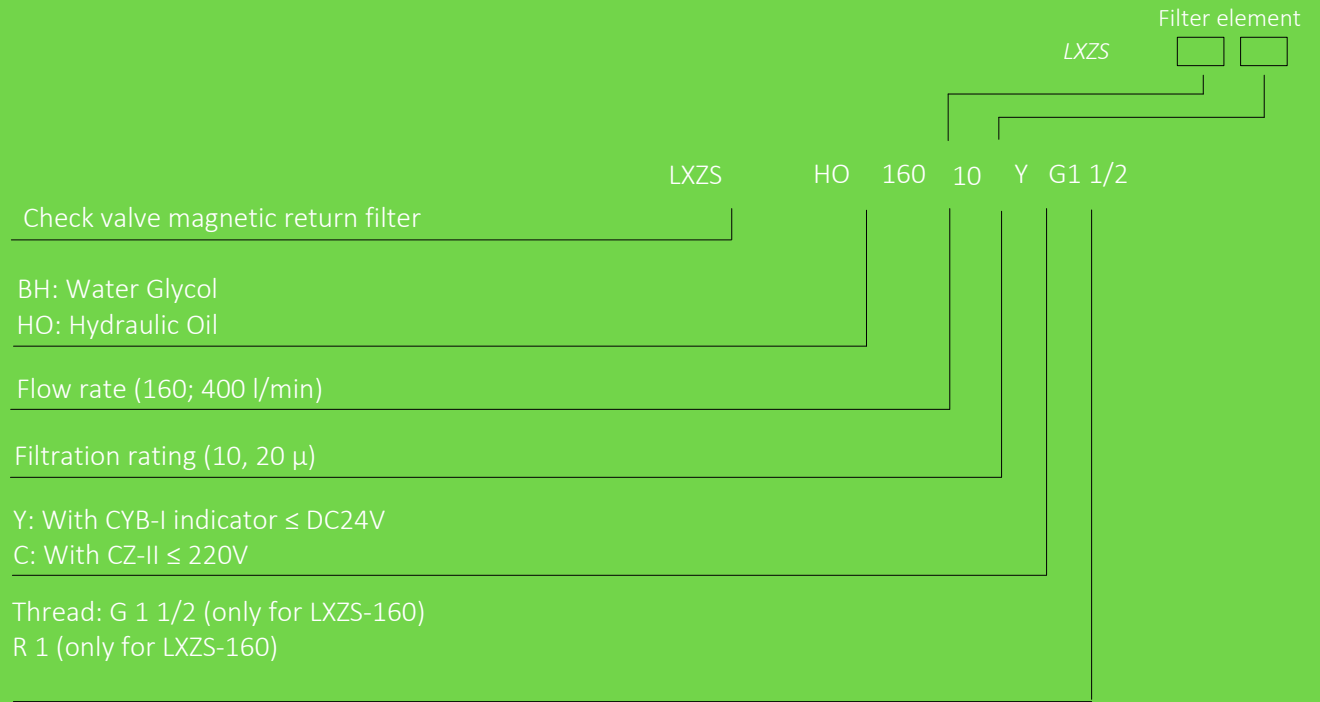

Unsure? Contact us.

Technical specification subject to change without prior notice. Other specification on request. 2013/07

Mounting size

LXZS-160

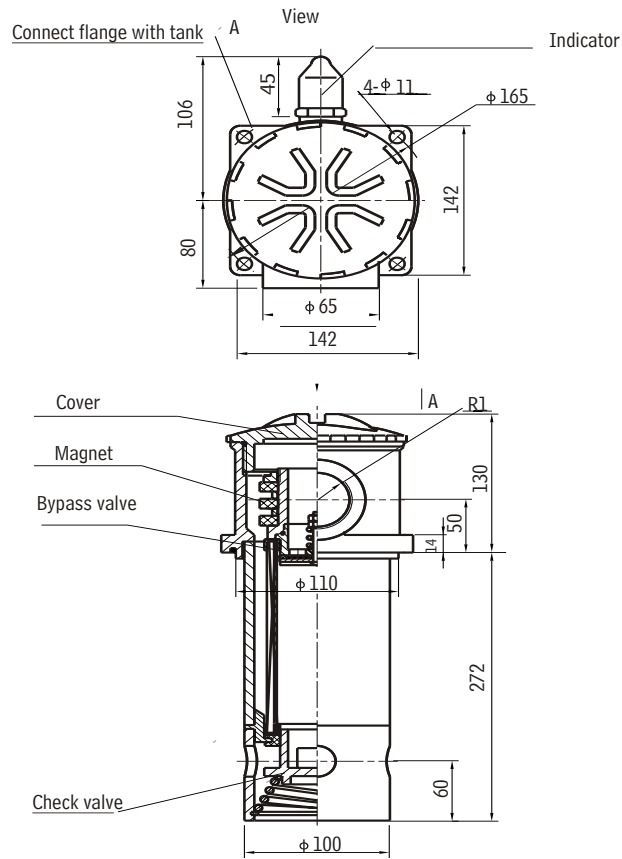

LXZS-400

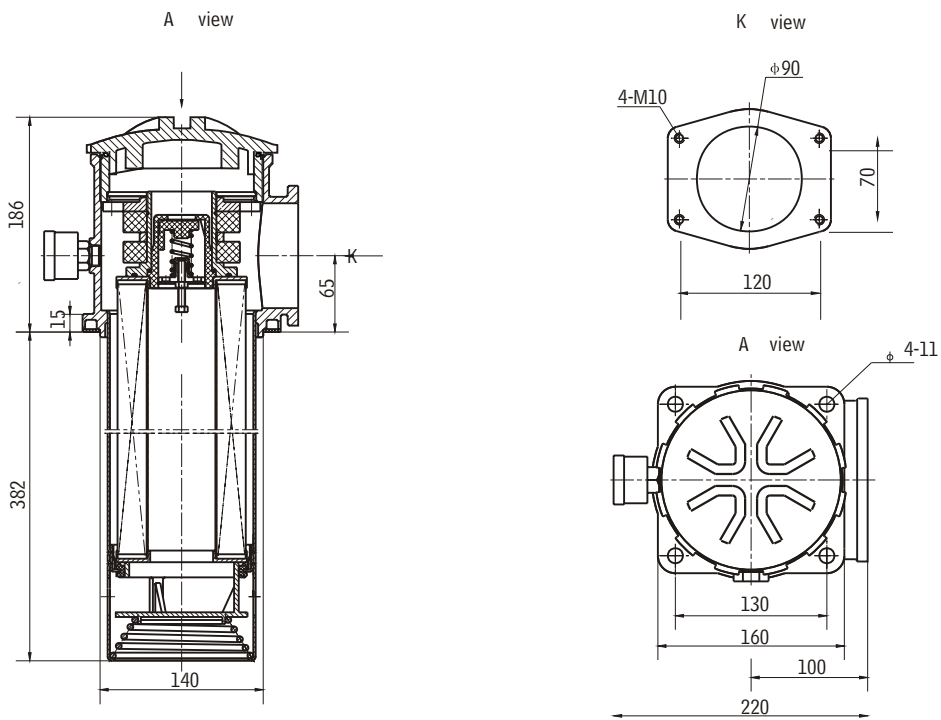

Technical specification subject to change without prior notice. Other specification on request 013/07/23

Notes

Technical specification subject to change without prior notice. Other specification on request. 2013/07

